

VER.	AMENDMENT	AUTHORISED BY	DATE

INTERESTS AND NOTIFICATIONS						
SUBJECT	PURPOSE	STATUTORY REFERENCE	ORIGIN	LAND BURDENED	BENEFIT TO	COMMENTS
Ⓔ	EASEMENT (SEWERAGE)	SECTION 167 OF THE P. AND D. ACT REG. 6	DP58609	LOT 148	WATER CORPORATION	
ⒺA	EASEMENT (SEWERAGE)	SECTION 167 OF THE P. AND D. ACT REG. 6	THIS PLAN	LOT 3001	WATER CORPORATION	
ⒺB	EASEMENT (UNDERGROUND ELECTRIC)	SECTION 167 OF THE P. AND D. ACT REG. 8	THIS PLAN	LOTS 139-141 & 166-174	ELECTRICITY NETWORKS CORPORATION	
	RESTRICTIVE COVENANT	SECTION 136D OF THE T.L.A.	DOC AND THIS PLAN	LOTS 139-148, 159-181, 190-196	LOTS 139-148, 159-181, 190-196	EXPIRES 30/6/2015
Ⓐ TO Ⓑ	RESTRICTIVE COVENANT	SECTION 129BA OF THE T.L.A.	DOC	LOTS 139-141	CITY OF WANNEROO	RESTRICTION OF ACCESS TO ROAD
Ⓒ TO Ⓓ	RESTRICTIVE COVENANT	SECTION 129BA OF THE T.L.A.	DOC	LOTS 166-171	CITY OF WANNEROO	RESTRICTION OF ACCESS TO ROAD
Ⓔ TO Ⓕ	RESTRICTIVE COVENANT	SECTION 129BA OF THE T.L.A.	DOC	LOTS 172-174	CITY OF WANNEROO	RESTRICTION OF ACCESS TO ROAD
LOT 3001	RESERVE FOR RECREATION	VESTS IN CROWN UNDER SEC. 152 OF THE P. AND D. ACT	THIS PLAN			
	MEMORIAL	SECTION 67B OF THE WATER AGENCIES (POWERS) ACT 1984	THIS PLAN	LOTS 139-148, 159-181, & 190-196	WATER CORPORATION	

LIMITED IN DEPTH TO 609.6 METRES AS TO LOT 1669 ONLY

NOTE:
ALL BOUNDARY / CORNER SURVEY MARKS SHOWN ON THIS SHEET ARE INDICATIVE ONLY. USE ONLY THE SURVEY SHEET WHEN DETERMINING THE TRUE FINAL POSITION AND TYPE OF ALL SURVEY MARKS PERTAINING TO THIS PLAN.

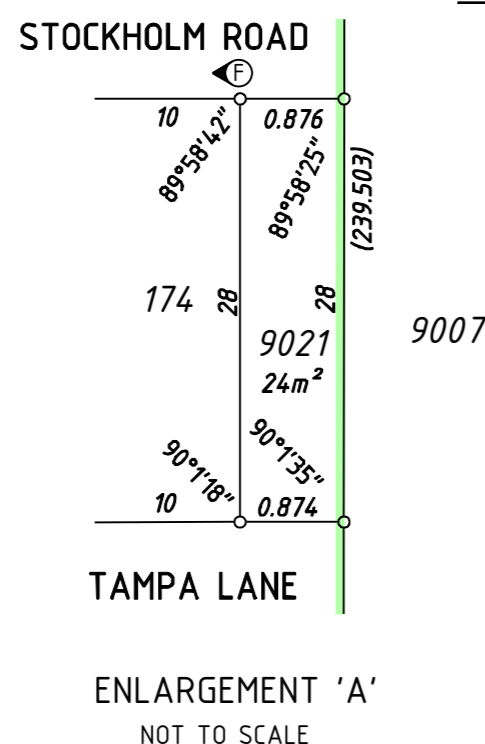
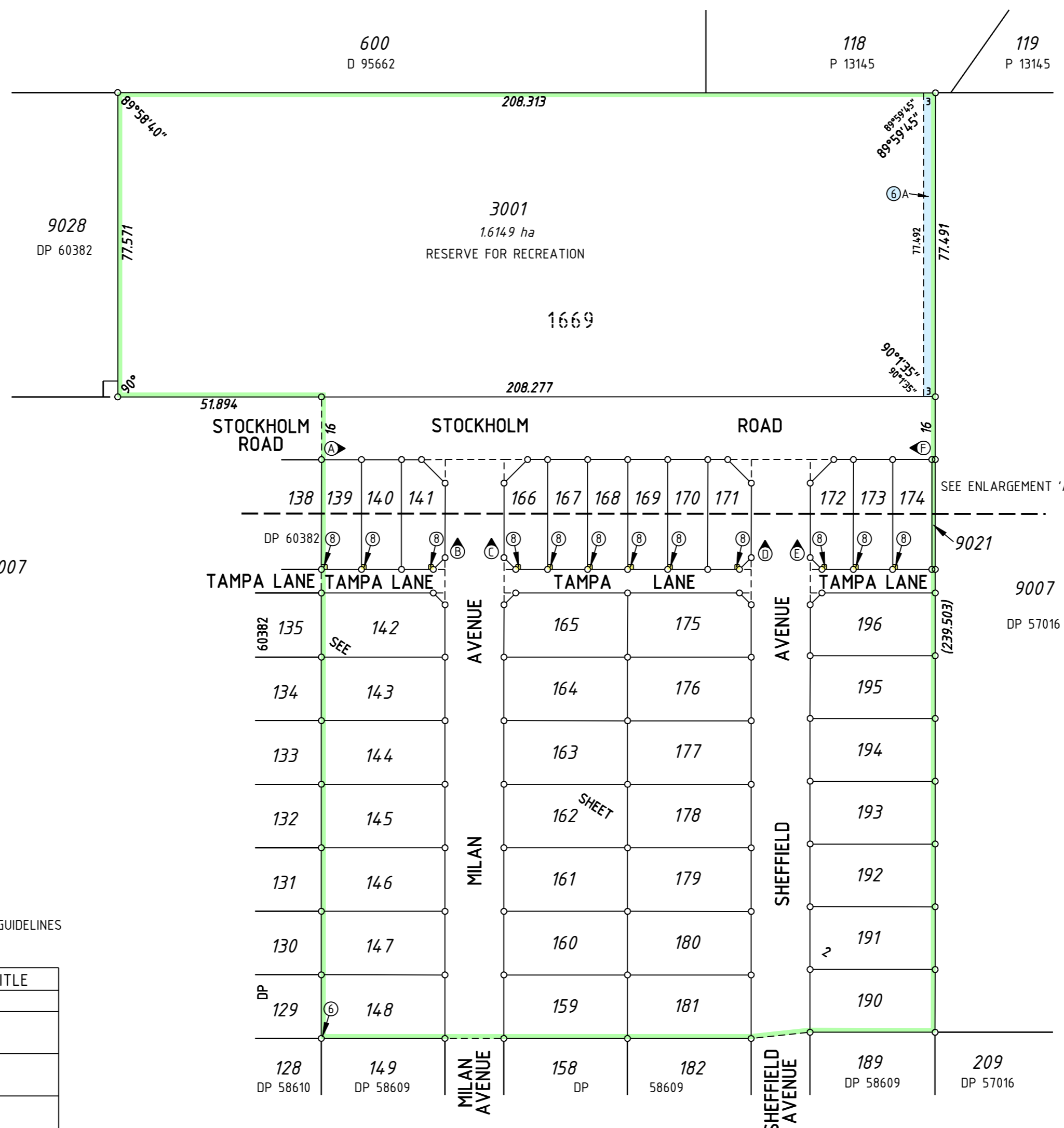

SURVEY CARRIED OUT UNDER REGULATION 26A SPECIAL SURVEY AREA GUIDELINES SEE SHEETS FOR SURVEY INFORMATION.

LOT	FORMER TENURE	ON PLAN/DIA	TITLE
139-148	PT LOT 9020	DP60382	
159-166	PT LOT 9011	DP58609	
	PT LOT 9020	DP60382	
167-181	PT LOT 9011	DP58609	
190-196, 9021			
3001	PT LOT 9011	DP58609	
	PT LOT 9020	DP60382	
	LOT 9019	DP60382	

TYPE	FREEHOLD
PURPOSE	SUBDIVISION
PLAN OF	
LOTS 139-148, 159-181, 190-196, 3001, 9021, ROADS, EASEMENTS & RESTRICTIVE COVENANT	
DISTRICT	SWAN
TOWNSITE	
FILE	
LOCAL AUTHORITY	CITY OF WANNEROO
LOCALITY	WANNEROO
INDEX	BG35(2) 11.06
FIELD BOOK	98174

SCALE: 1:1000	0 10 20 30 40 50 60
AT A2 SIZE	
ALL DISTANCES ARE IN METRES	

SURVEYOR'S CERTIFICATE - Reg 54
MAX HORE
I hereby certify that this plan is accurate and is a correct representation of the - (a) * survey; and/or (b) * calculations from measurements, undertaken for the purposes of this plan and that it complies with the relevant written law(s) in relation to which it is lodged. (* delete if applicable)

SURVEYOR'S CERTIFICATE - Compiled
I hereby certify that this compiled plan (a) is a correct and accurate representation of the survey(s) of the subject land; and (b) is in accordance with the relevant law in relation to which it is lodged.

Licensed Surveyor Date
SURVEY FIRM
FUGRO
FUGRO SPATIAL SOLUTIONS Pty. Ltd.
18 PROWSE STREET
WEST PERTH, W.A., 6005
TEL. (08) 9282 4100
FAX. (08) 9322 1775
BELVERDERE HILLS STAGE 8
PLAN No. 6618579-21 REV.6

LODGED	TYPE OF VALIDATION	APPROVED BY
DATE	FULL AUDIT	WESTERN AUSTRALIAN PLANNING COMMISSION
FEE PAID	LEGAL COMPONENT	FILE 132483, 132488
ASSESS No.	DOCKET	DELEGATED UNDER S16 P & D ACT 2005
	CERTIFIED CORRECT	DATE
	I.S.C.	
	F.S.C.	

IN ORDER FOR DEALINGS

SUBJECT TO

FOR INSPECTOR OF PLANS & SURVEYS / AUTHORISED LAND OFFICER DATE

APPROVED REG 26A (4)

INSPECTOR OF PLANS & SURVEYS / AUTHORISED LAND OFFICER DATE



DEPOSITED PLAN
60383
SHEET 1 OF 4
VERSION 1

3001
1.6149 ha
RESERVE FOR RECREATION
1669

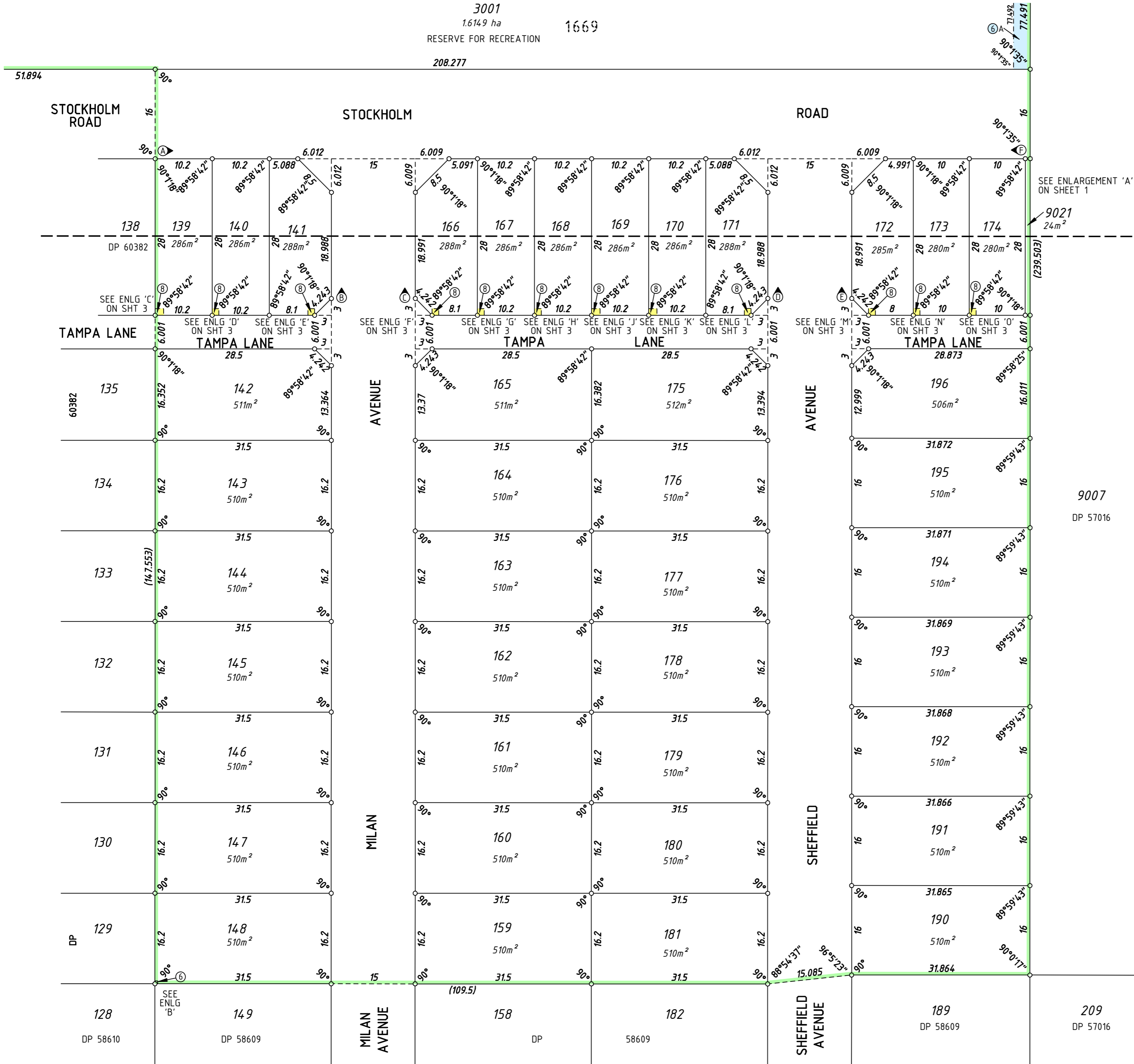

SEE ENLARGEMENT 'A'
ON SHEET 1

9021
24m²

9007
DP 57016

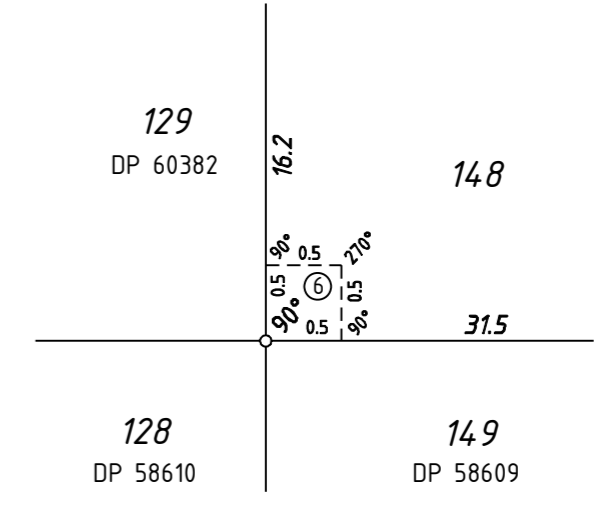

ENLARGEMENT 'B'
SCALE 1:50

SCALE: 1:500
AT A2 SIZE
ALL DISTANCES ARE IN METRES



Licensed Surveyor	Date
FUGRO SPATIAL SOLUTIONS 66/18575-21 Rev:6	
APPROVED BY WESTERN AUSTRALIAN PLANNING COMMISSION	
FILE	132483, 132488
DELEGATED UNDER S16 P & D ACT 2005	
DATE	
SHEET	2 OF 4
VERSION	1

Landgate
Western Australian Land Information Authority

DEPOSITED PLAN
60383

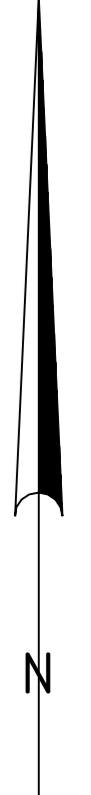

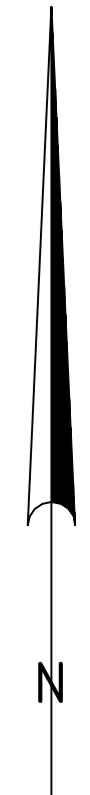
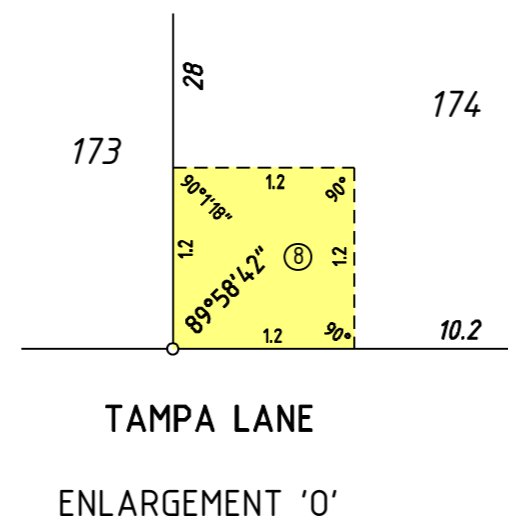
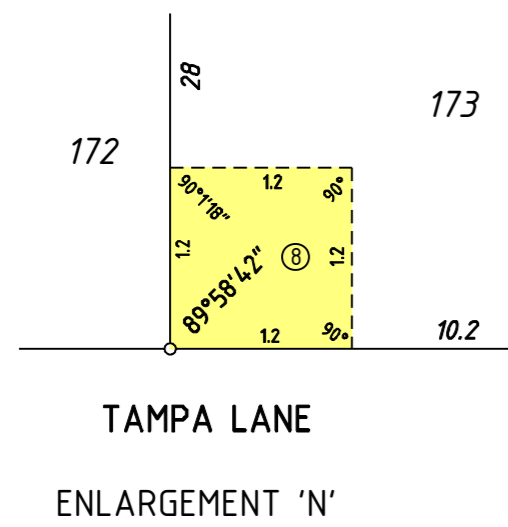
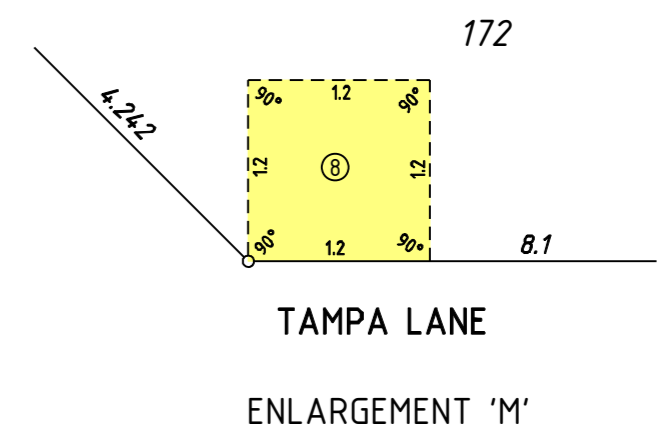
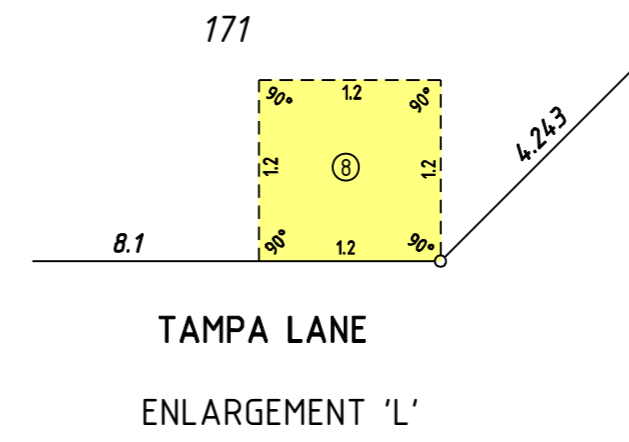
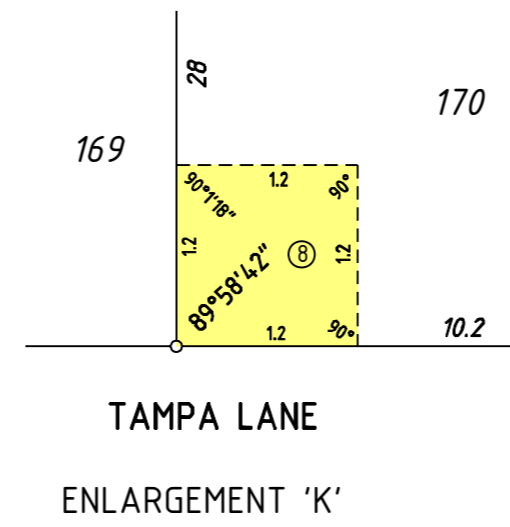
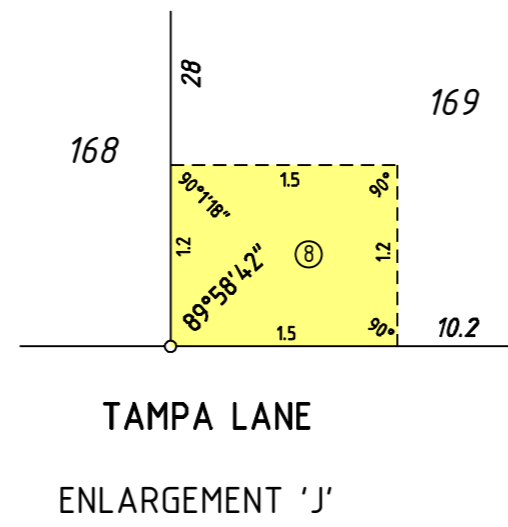
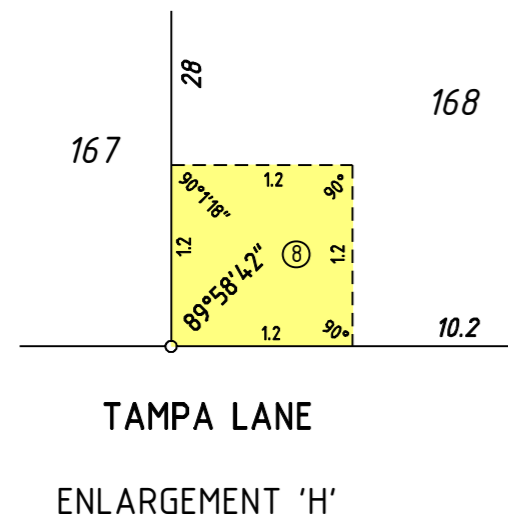
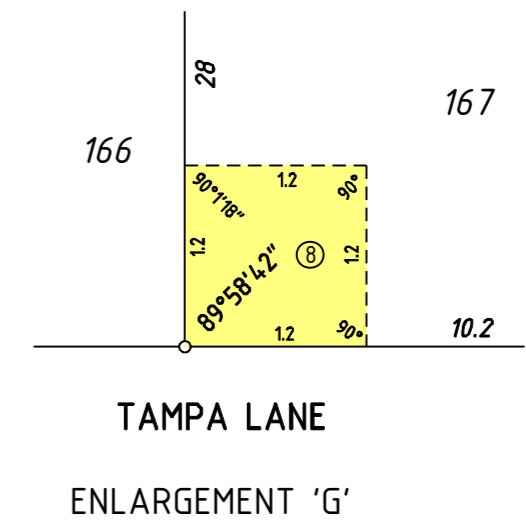
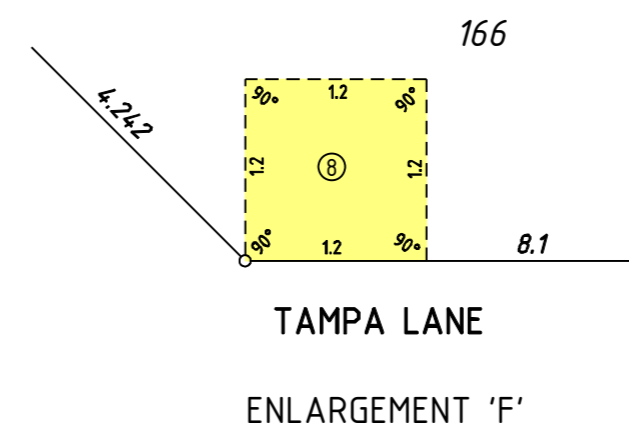
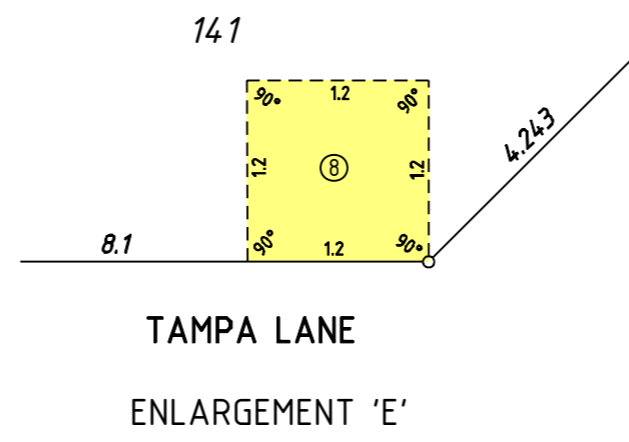
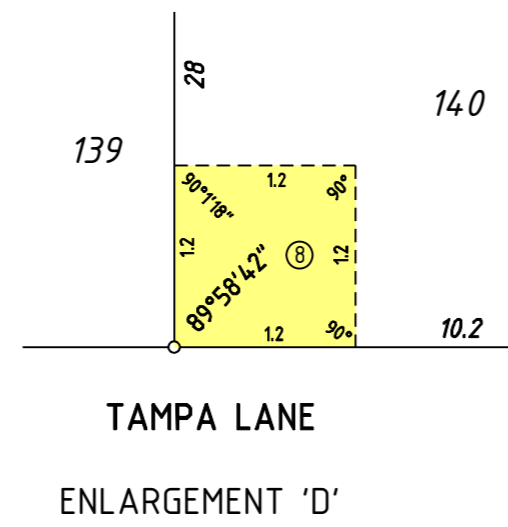
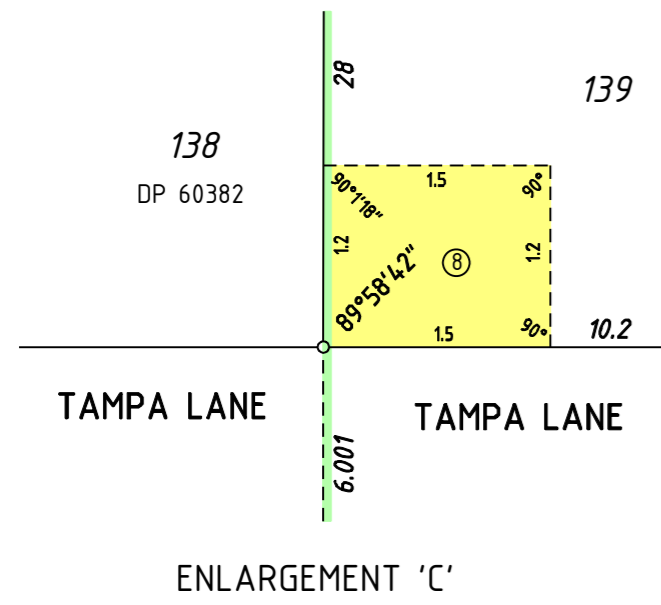

SCALE: 1:50
AT A2 SIZE
ALL DISTANCES ARE IN METRES

Licensed Surveyor _____ Date _____
FUGRO SPATIAL SOLUTIONS 66/18575-21 Rev:6
APPROVED BY
WESTERN AUSTRALIAN PLANNING COMMISSION
FILE 132483, 132488
DELEGATED UNDER S16 P & D ACT 2005
DATE _____
SHEET 3 OF 4
VERSION 1

Landgate
Western Australian Land Information Authority

DEPOSITED PLAN
60383

FOR HEADING SEE SHEET 1
 SURVEY INFORMATION ONLY
 SURVEY SHEET

SURVEY CARRIED OUT UNDER REGULATION 26A SPECIAL SURVEY AREA GUIDELINES
 BEARINGS DATUM - PCG94
 eFB 108950

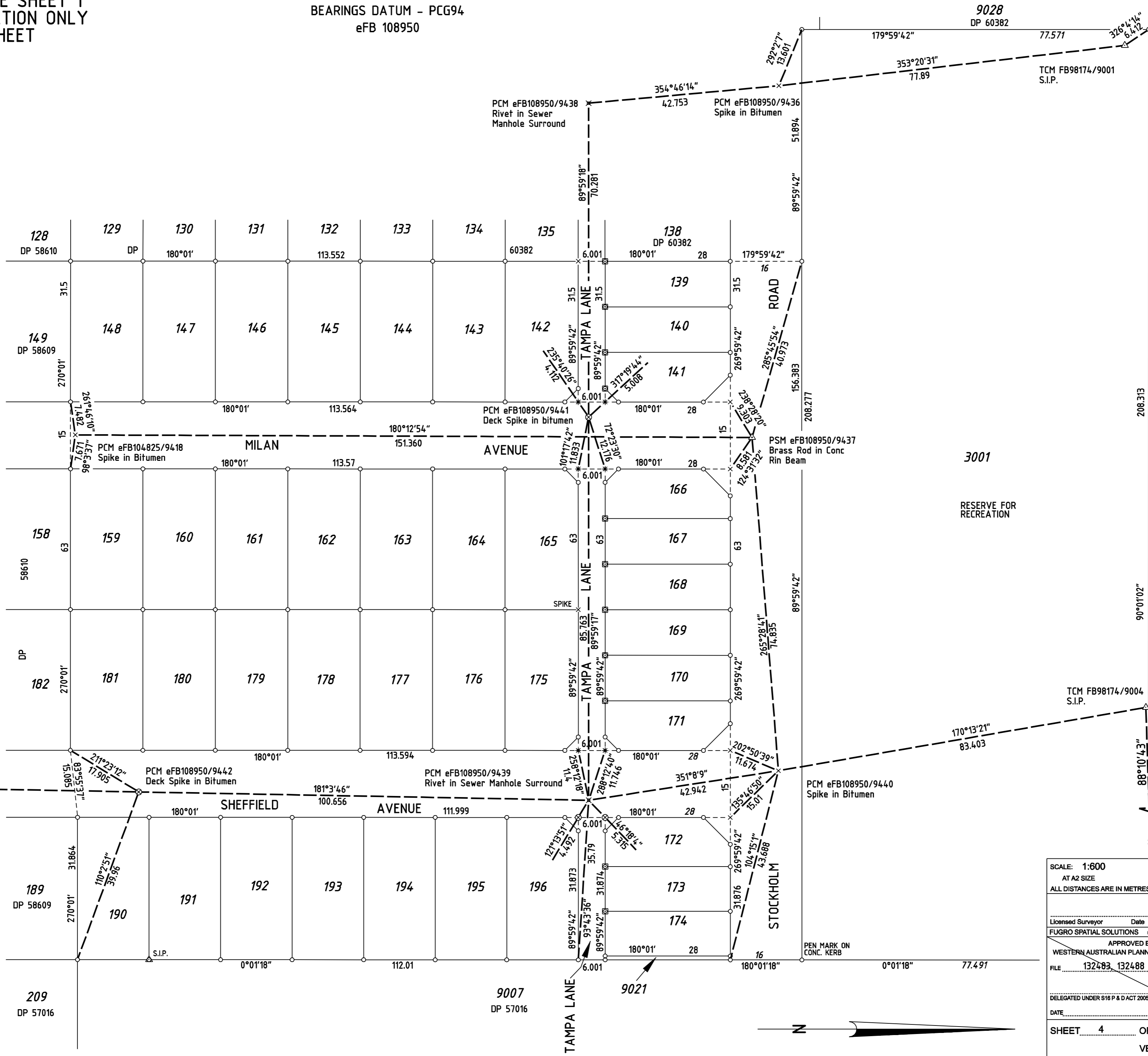

600
 D 95662

3001
 RESERVE FOR RECREATION

- SURVEY MARK LEGEND**
- △ Standard Survey Mark (SSM)
 - △ Permanent Survey Mark (PSM)
 - Peg unless stated otherwise
 - Nail
 - Concrete Nail
 - ⊗ Deck Spike in Bitumen
 - × Spike
 - ⊗ Nail & Plate
 - × Rivet
 - * Drill Hole in Kerb
 - △ Star Iron Picket

SCALE: 1:600
 AT A2 SIZE
 ALL DISTANCES ARE IN METRES

Licensed Surveyor	Date
FUGRO SPATIAL SOLUTIONS	66/18575-21 R:6
APPROVED BY WESTERN AUSTRALIAN PLANNING COMMISSION	
FILE	132483, 132488
DELEGATED UNDER S16 P & D ACT 2005	
DATE	
SHEET	4 OF 4
VERSION	1

Landgate
 Western Australian Land Information Authority

DEPOSITED PLAN
60383